

New Ingeo products offer structure and property capabilities that enhance performance in fiber / nonwovens, injection molding and durables markets

Jed Randall
NatureWorks LLC

Innovation Takes Root 2012

ingenious materials from plants not oil



Outline

- Review of PLA crystallization properties as a function of stereo composition
- NatureWorks future Ingeo grade offerings
- Crystallization properties of Ingeo new grades
- Melt blown fiber research
- Spun bond fiber research
- Injection molding and durables opportunities
- Timeline for commercialization



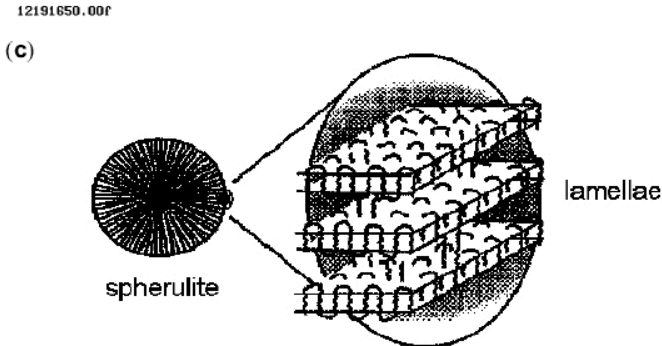
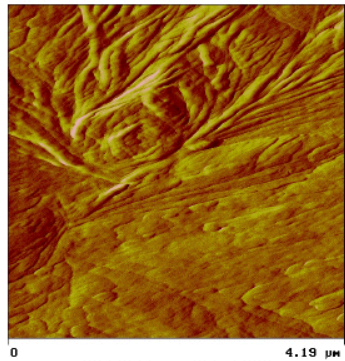
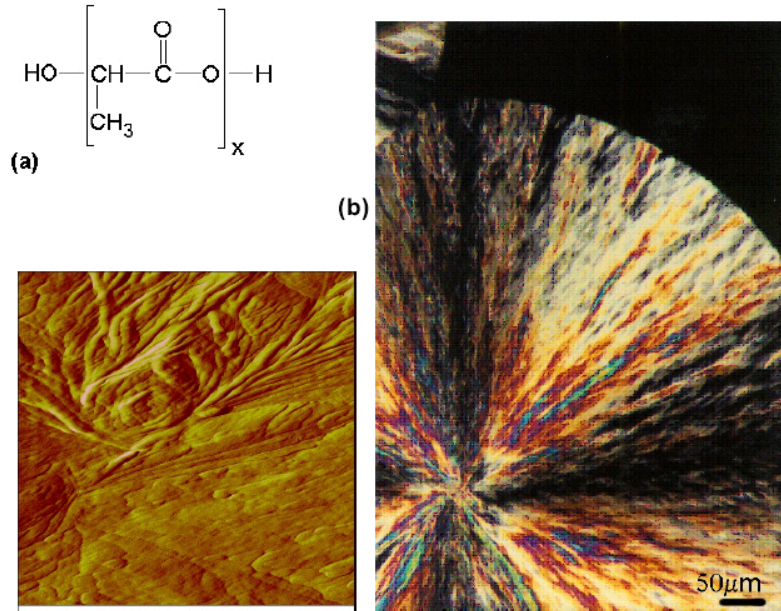

*from Pyda, et al. (2002)

- Generally spherulitic
- Follows Avrami kinetics

$$k = \frac{4}{3} \pi N G^3 \quad x = 1 - e^{-kt^n}$$

Where x = fraction of crystallinity and n=3

- Dominated by slow crystal growth, G
- Enhanced by nucleation, N
- Size of spherulites after impingement is dominated by N
- Applied when crystallizing pellets or annealing processes
- Highly sensitive to optical comp. and T
- ΔH of pure crystal = -93.1 J/g



Radial crystal growth rate, $G(T)$ for PLLA (generally 0-0.3% D)

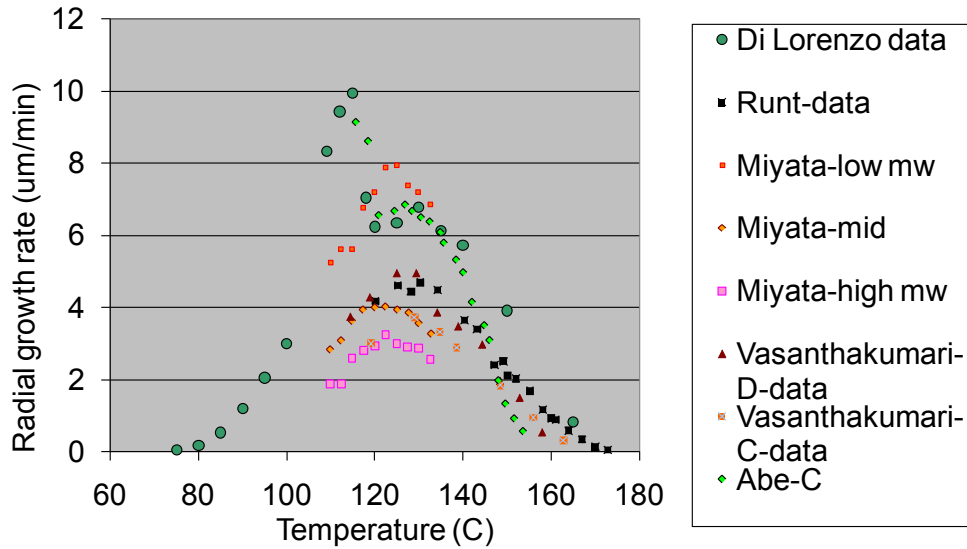

← Raw data from literature

Scaled data (at 130°C) for MW and experiment differences

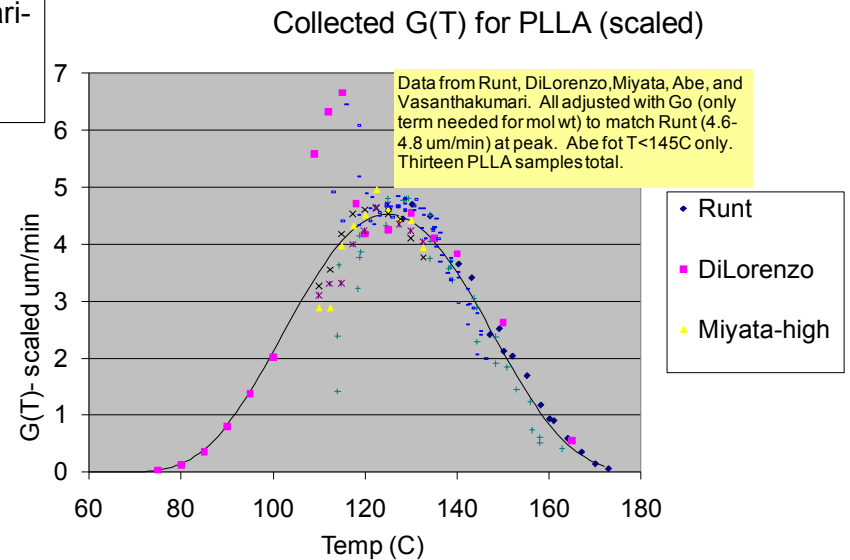

Melting point is a function of crystallization temperature (T_c) Shown for random poly(L-lactide-co-D-lactides)*

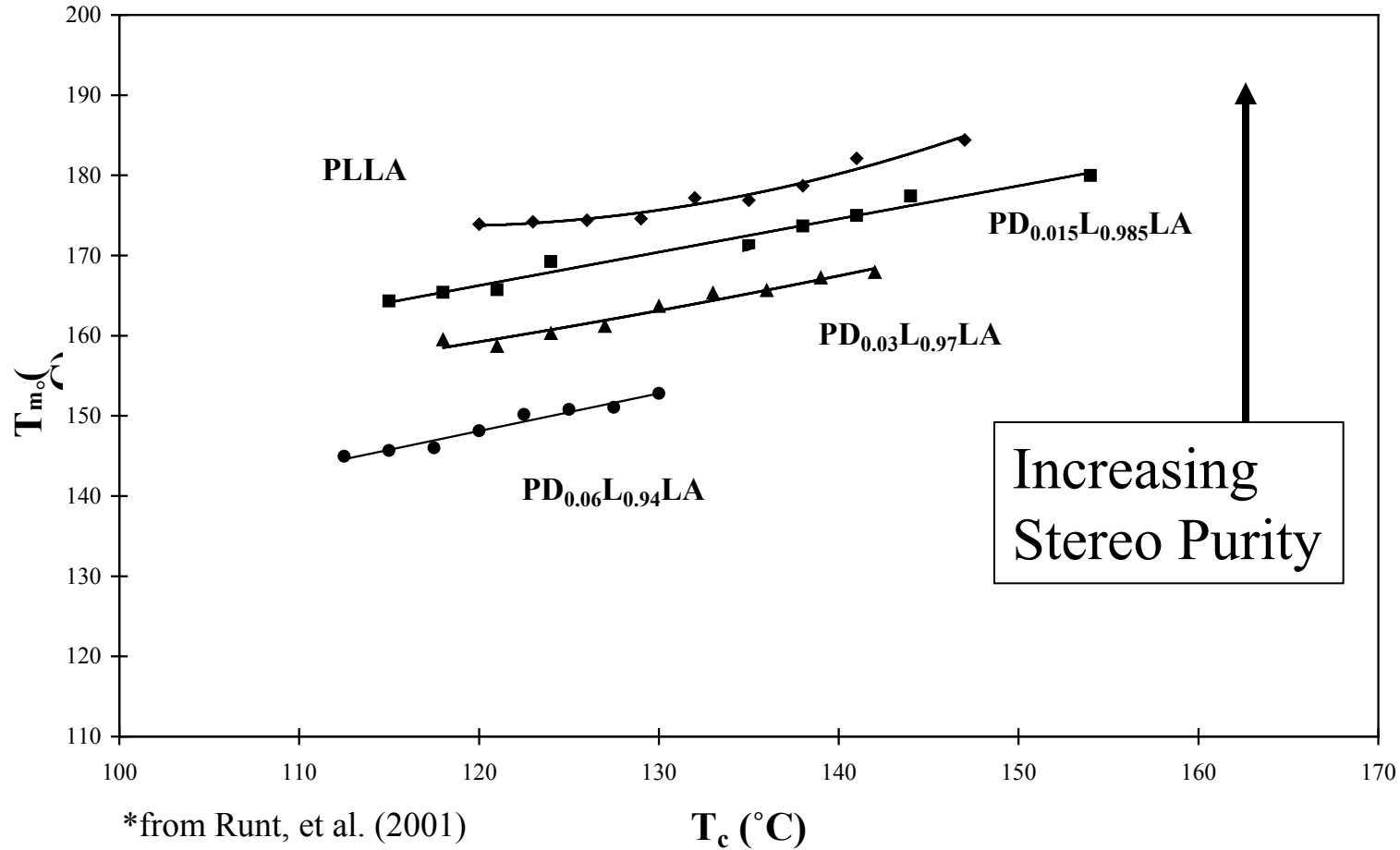

In summary, increasing %D isomer results in...

- Depression of the melting point
- Reduction in the level of attainable crystallinity
- Reduction in the rate of crystallization
- Change stress-strain behavior between T_g and T_m
- Reduction in modulus above T_g when crystalline
- Above ~10%D polymer does not crystallize in most practical processes



8000 series
foam

7000 series
bottles - ISBM

6000 series
fibers & nonwovens

4000 series
films

3000 series
injection Molding

2000 series
thermoforming

Lactide monomer



Basic Design Table – Ingeo Grades

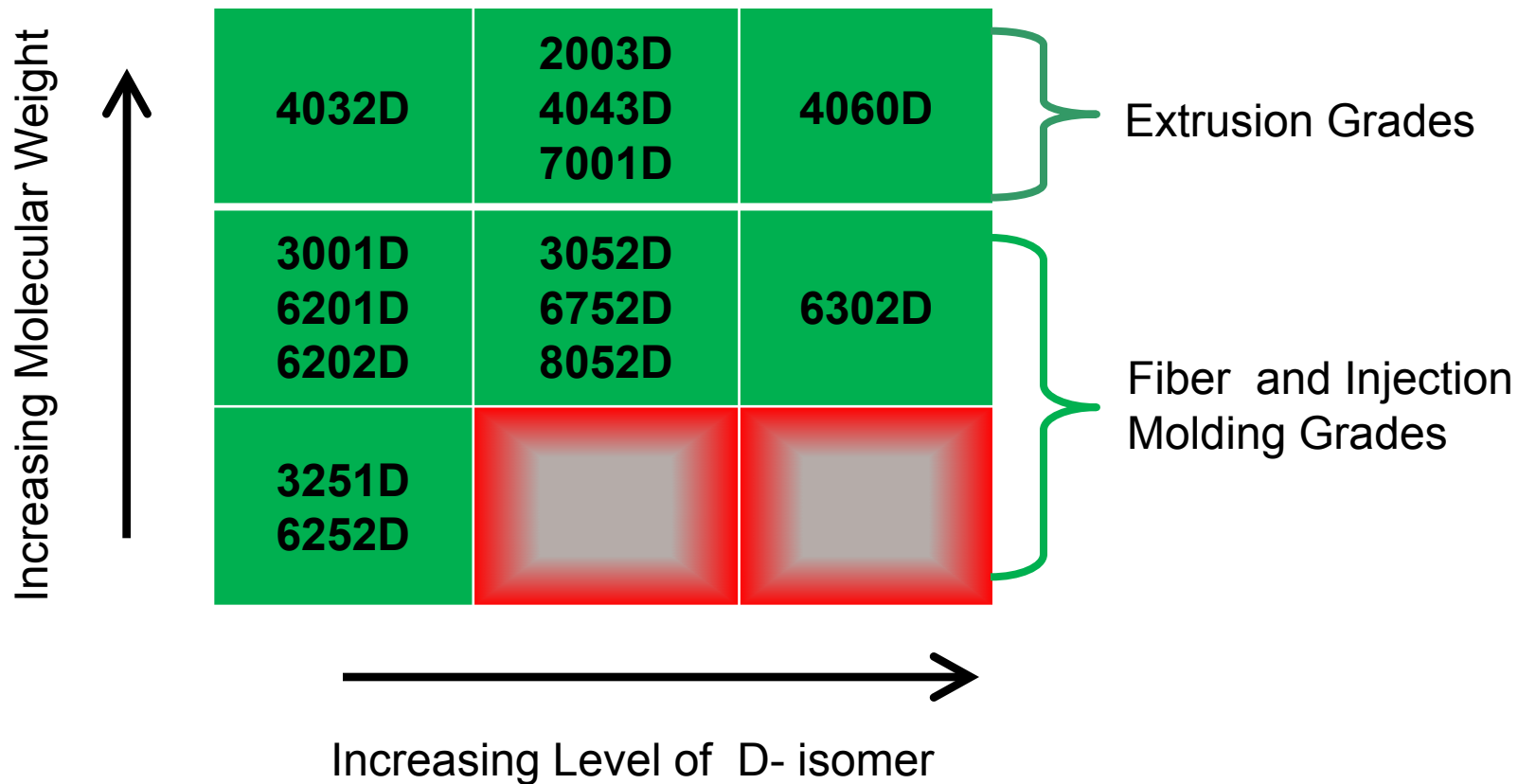

Expanded Design Table – Ingeo Grades

Increasing Molecular Weight ↑

Increasing Molecular Weight ↑	In Development	4032D	2003D 4043D 7001D	4060D	Extrusion Grades
	3100HP 6100D	3001D 6201D 6202D	3052D 6752D 8052D	6302D	
	3260HP 6260D	3251D 6252D			

Increasing Level of D- isomer →



Properties of New High %L Ingeo Grade Offering



High %L Crystal Growth Rate Results

Hot stage microscopy measuring lineal crystal growth rate

#	%D	RV
6100D	0.3	3.1
6201D	1.5	3.1

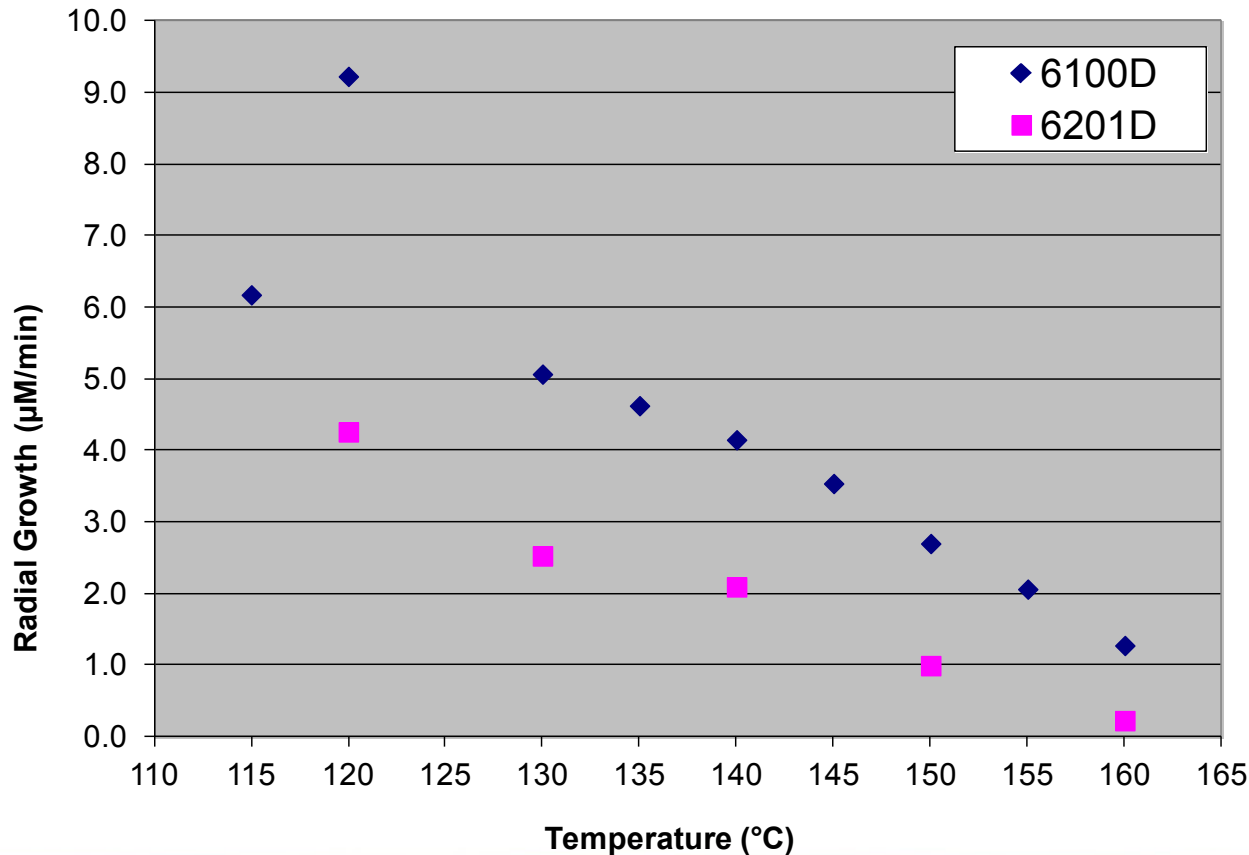

Crystal radial growth shows > 2x increase as $f(T)$ over today's product offering



Bulk crystallization: nucleation study

- Crompton, Kemamide EBS at 0.5 wt%
 - ethylene-bis-stearamide
 - 140°C T_m , flash point 280°C
- Nissan Chemical, Ecopromote at 1.0 wt%
 - phenylphosphonic acid, zinc salt
 - decomposition >500°C
- Takemoto Oil & Fat, LAK-301 at 1.0 wt%
 - aromatic sulfonate derivative
- Specialty Minerals, Ultratalc 609 at 0.5 wt%
 - 0.9 μm mean particle size Montana talc, untreated



Bulk Crystallization by Flash DSC 1 from Mettler



Specifications - Flash DSC 1 - Flash Differential Scanning Calorimeter

Temperature range	Air cooling (Room temperature + 5 K) ... 500 °C IntraCooler (1-stage) -35 °C ... 450 °C IntraCooler (2-stage) -95 °C ... 420 °C
Cooling rates (typical)	-6 K/min. (-0.1 K/s) ... -240 000 K/min (-4 000 K/s)
Heating rates (typical)	30 K/min. (0.5 K/s) ... 2 400 000 K/min (40 000 K/s)
Sensor material	Ceramic
Thermocouples	16
Sample size	10 ng ... 1 µg
Sampling rate	Max. 10 kHz (10 000 points per second)

“Flash DSC is a novel technique, a quantum leap in DSC technology that opens up new frontiers. The Flash DSC 1 revolutionizes rapid-scanning DSC thanks to its ultra-high heating and cooling rates. The state-of-the-art instrument can easily analyze reorganization and crystallization processes which were previously difficult or impossible to measure. The Flash DSC 1 is the ideal complement to conventional DSC for characterizing modern materials and optimizing production processes by thermal analysis.”

-Mettler web site



Isothermal Methods

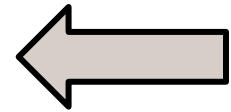
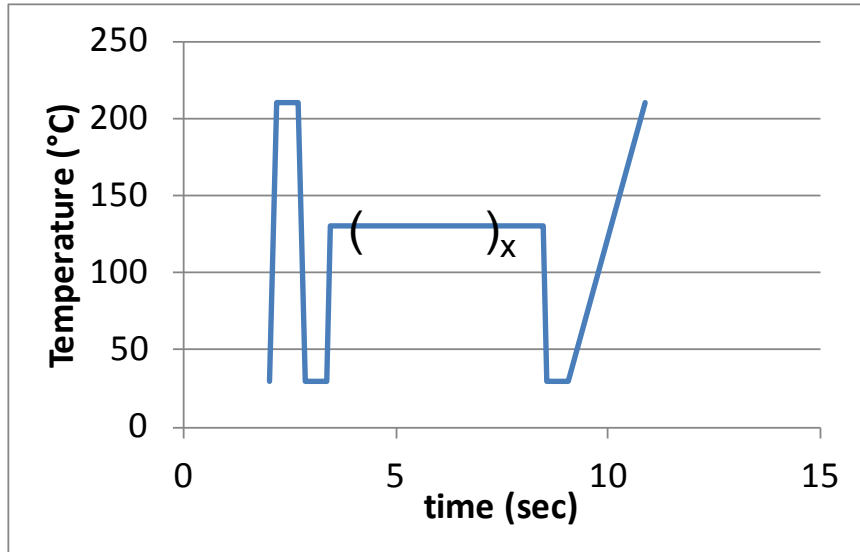

Isotherm after quench
 $x = 5 - 600$ s
 Measure changes at 100°C/s

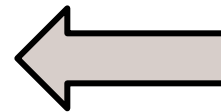
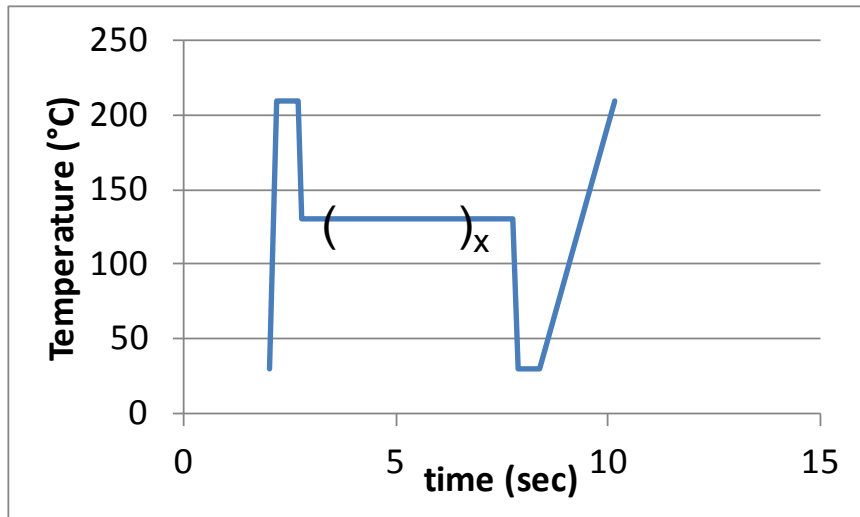

Isotherm after melt
 $x = 5 - 600$ s
 Measure changes at 100°C/s



Dynamic Methods

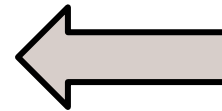
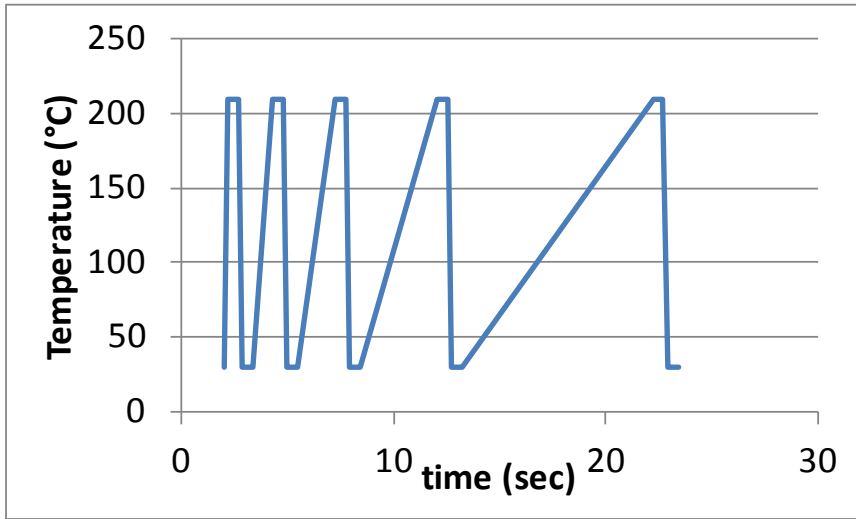

Varied heating rates
0.333 to 2000°C/s

Measure crystallization and
melting during heating

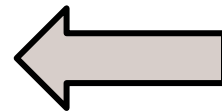
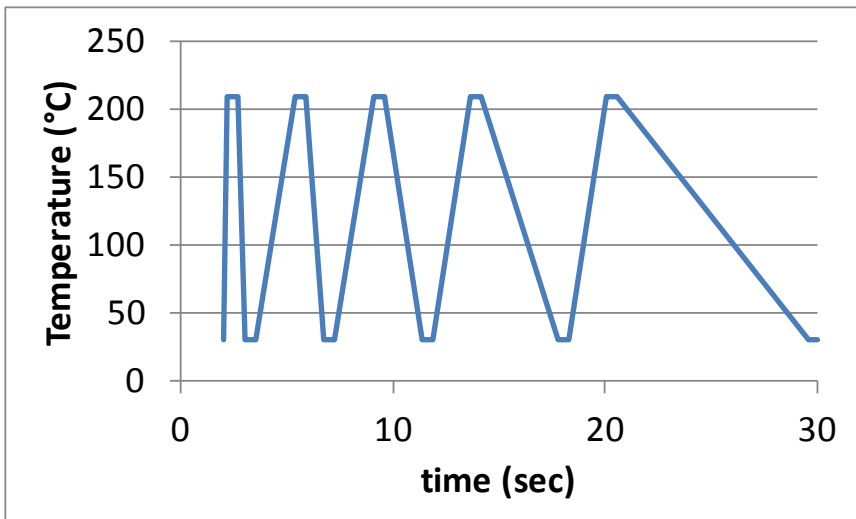

Varied cooling rates
-0.333 to -2000°C/s

Measure cooling history
at 100°C/s reheat



Flash DSC example of collected data 1: Reheat at 100°C/sec after annealing 5-600 seconds at 130°C from quenched state (30°C)

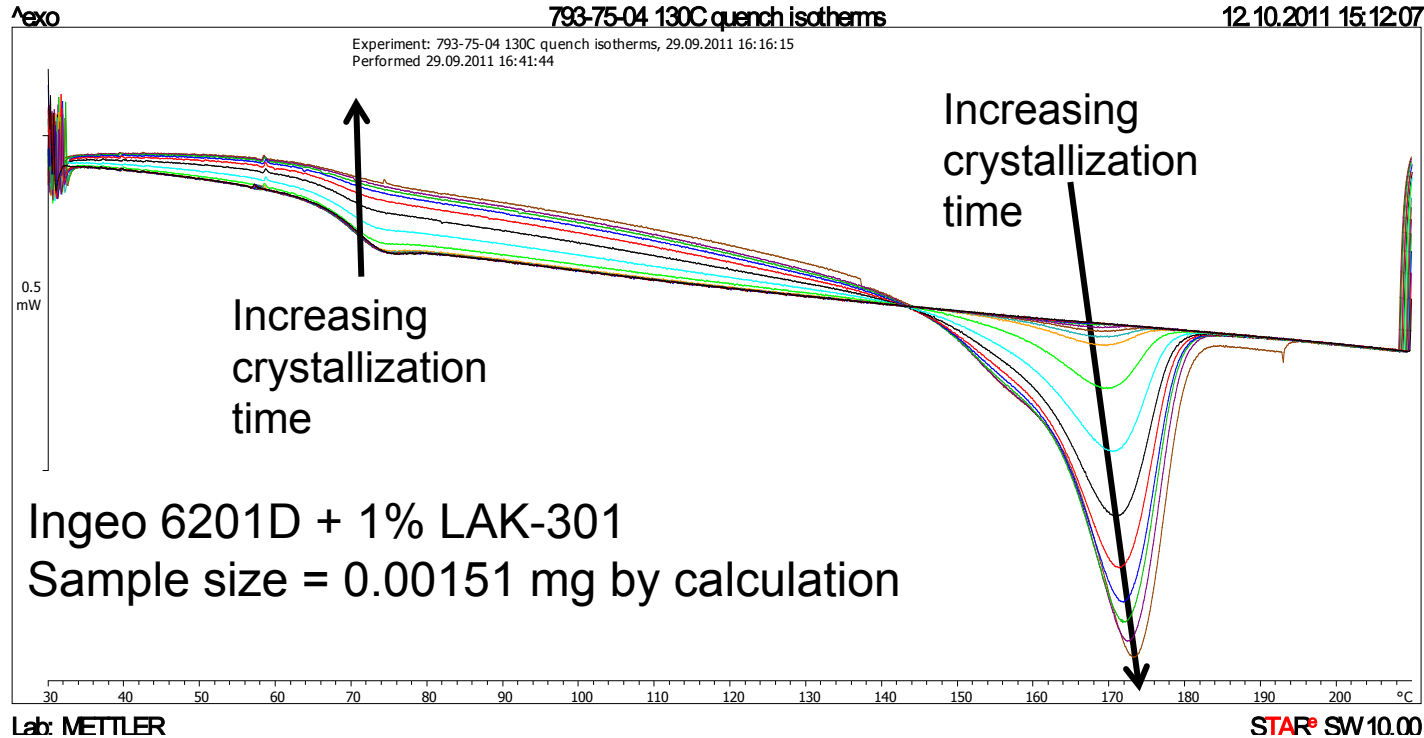

- Heating rate is fast enough to prevent cold crystallization during measurement
- Melting peak enthalpy and temperature increase with time
- Glass transition ΔC_p shrinks with time

Effect of impingement and secondary crystallization processes on crystallinity

Simulation showing free growth, Avrami, and effect of secondary crystallization

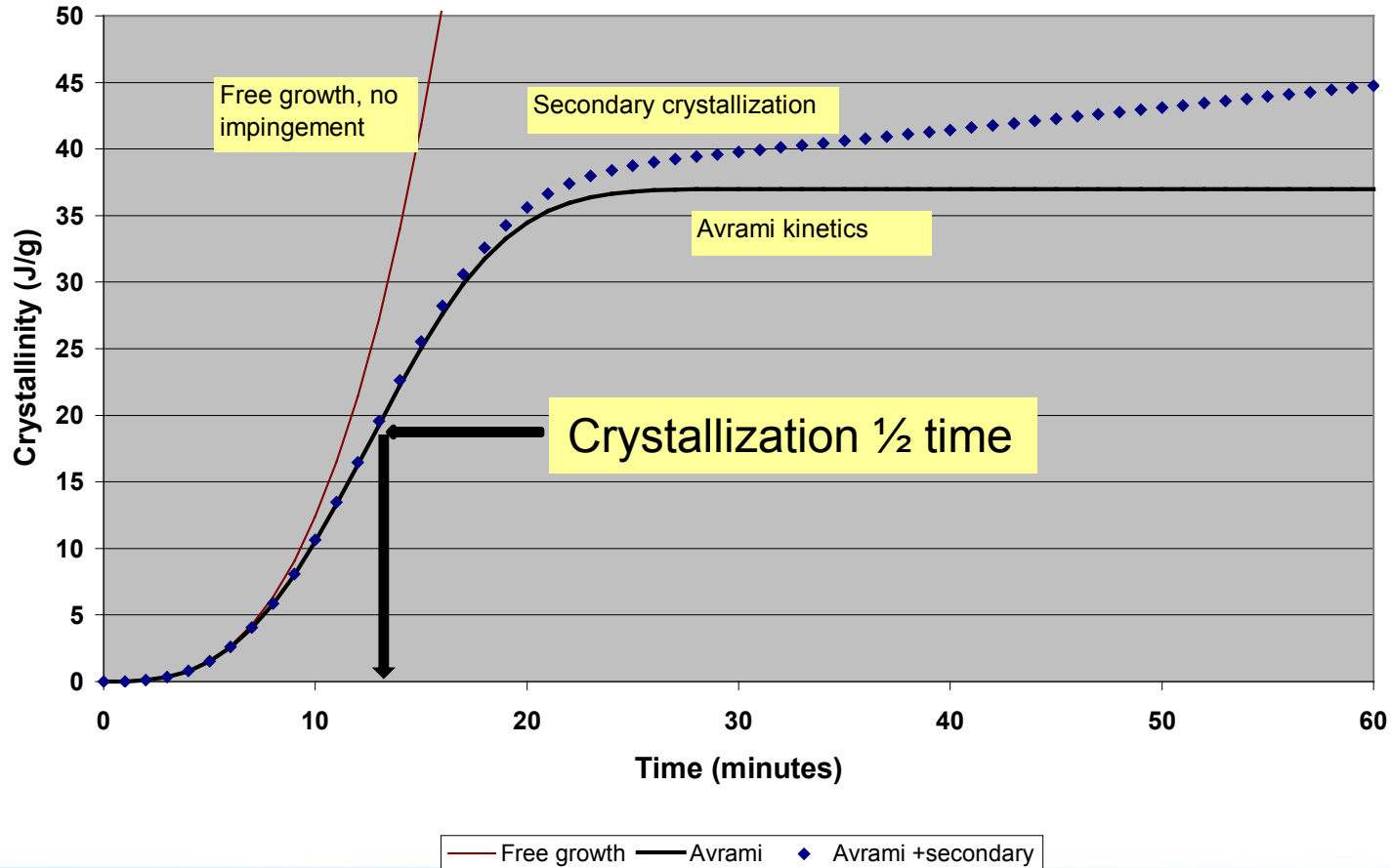

Isothermal Crystallization Temperature Effects

Ingeo 6201D (~1.5%D) vs. 6100D (~0.3%D) at equal MW

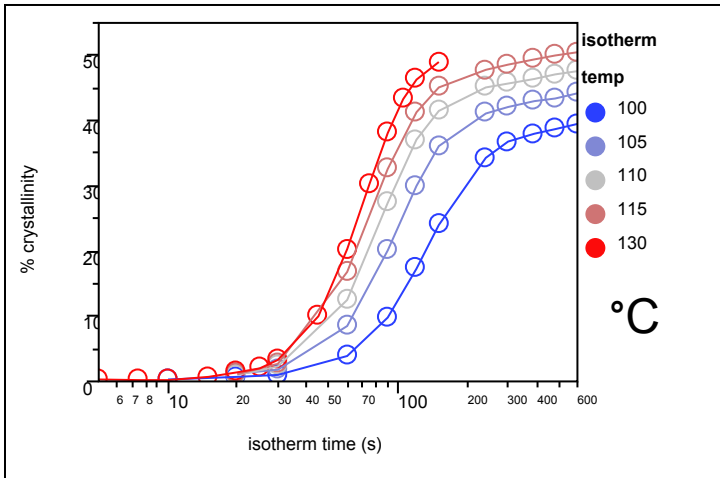

← 6201D + 1% LAK-301
5-600 seconds at varied temp.
From the quench state (30°C)

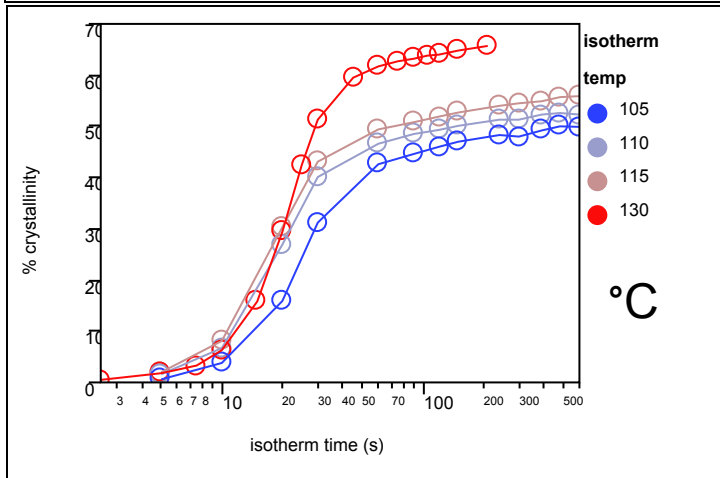

← 6100D + 1% LAK-301
5-600 seconds at varied temp.
From the quench state (30°C)

Tested using 1% LAK-301 Nucleant from Takemoto Oil & Fat
100% PLA crystal = -93 J/g



Neat polymer (no nucleant) crystallized from the melt and quenched states

Bivariate Fit of cryst 1/2 time [s] By isotherm temp Nucleant=neat

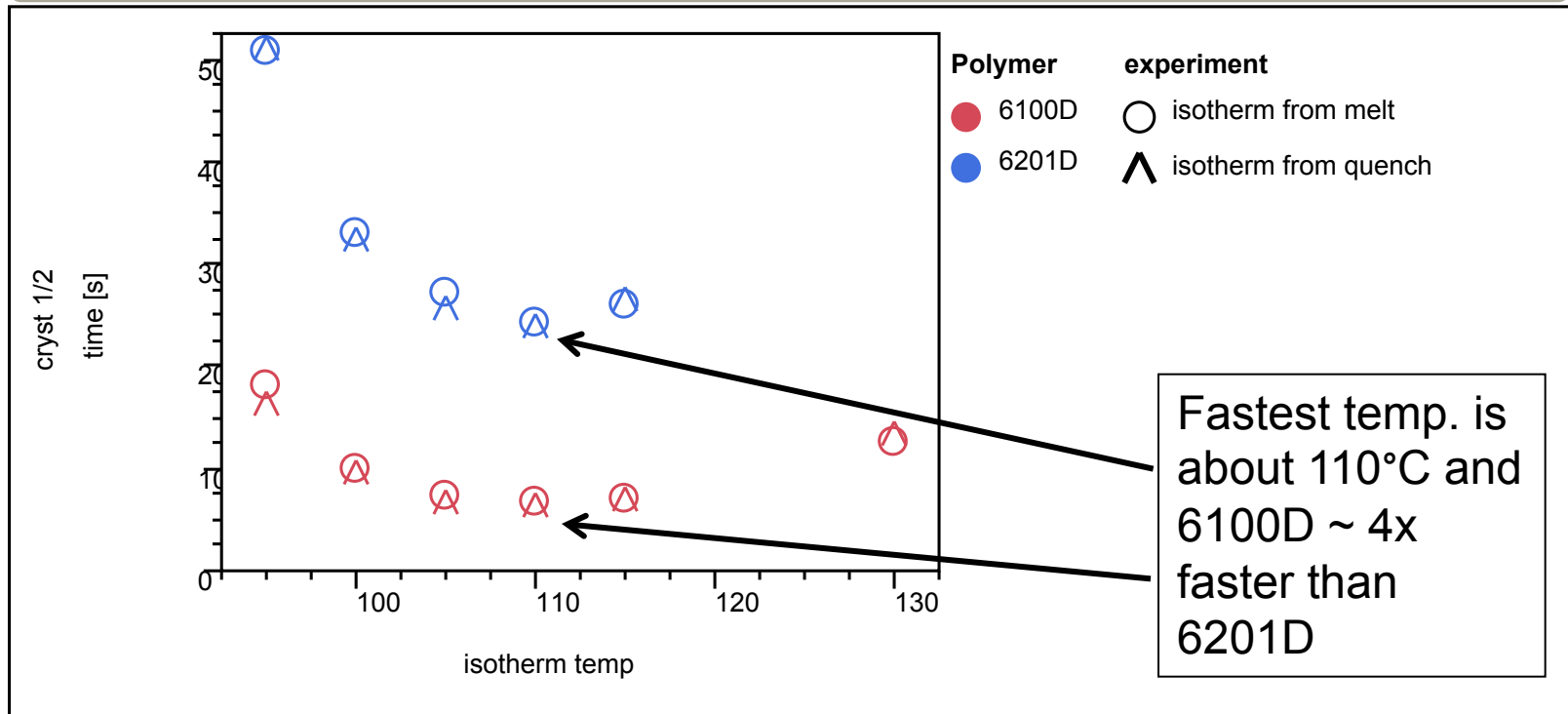

1.0% LAK-301 nucleant crystallized from the melt and quenched states

Bivariate Fit of cryst 1/2 time [s] By isotherm temp Nucleant=1% LAK-301

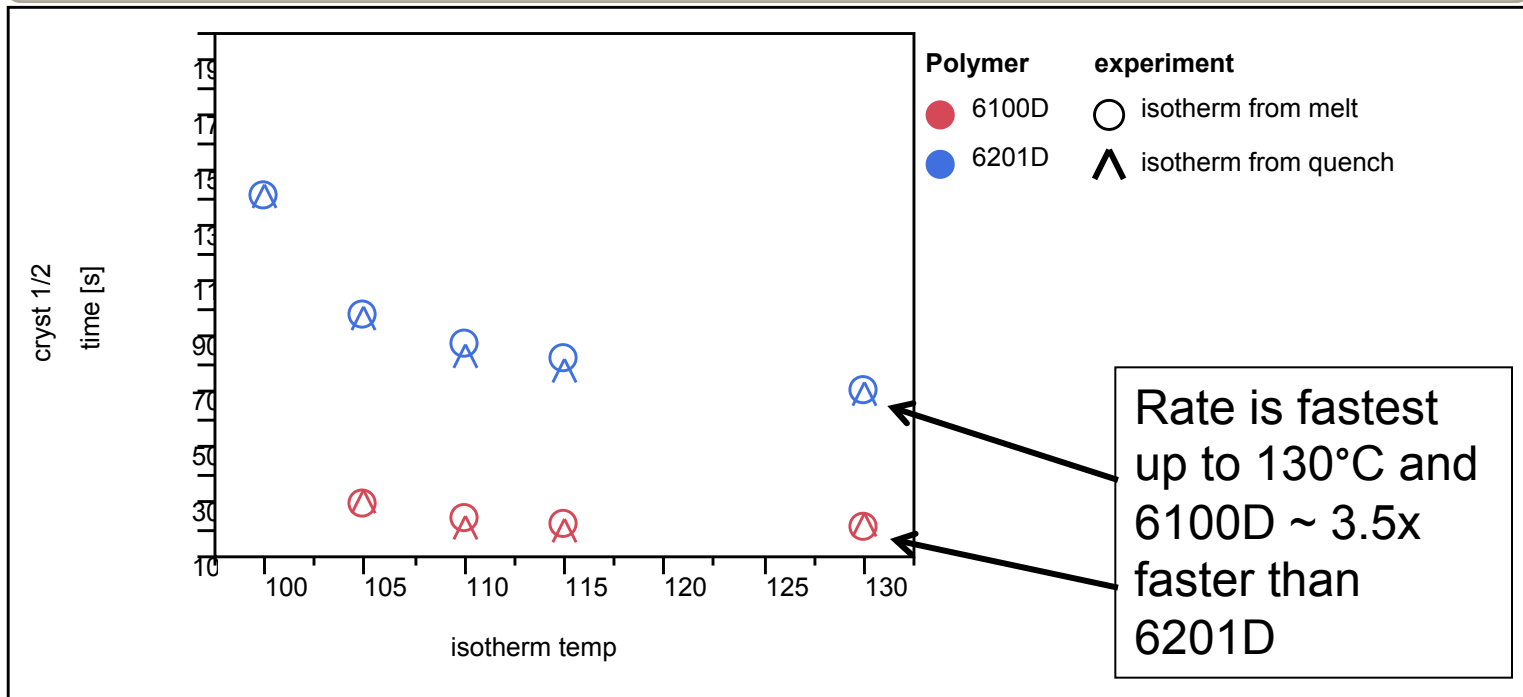

LAK-301 supplied by Takemoto Oil & Fat



1.0% Ecopromote nucleant crystallized from the melt and quenched states

Bivariate Fit of cryst 1/2 time [s] By isotherm temp Nucleant=1% Ecopromote

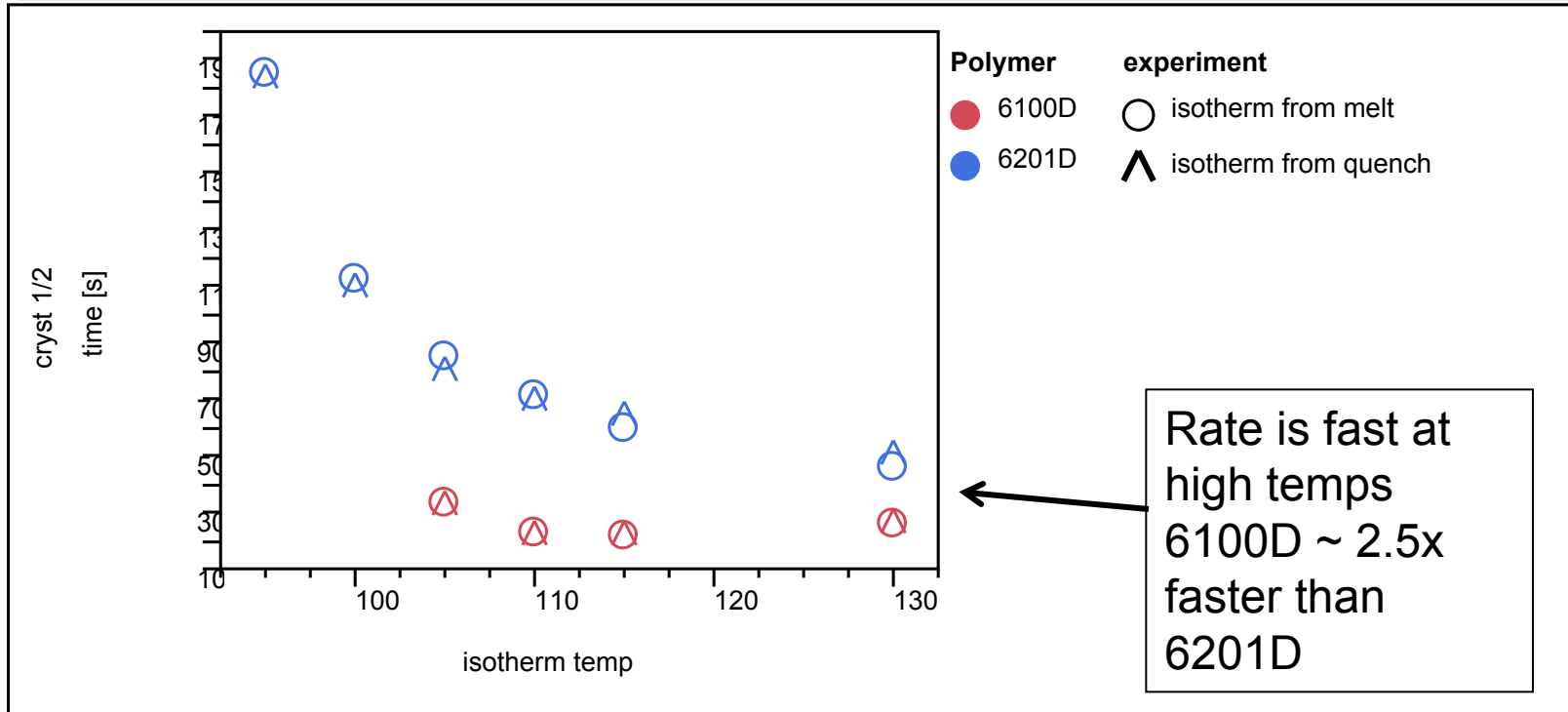

Ecopromote supplied by Nissan Chemical



0.5% talc nucleant crystallized from the melt and quenched states

Bivariate Fit of cryst 1/2 time [s] By isotherm temp Nucleant=0.5% Talc

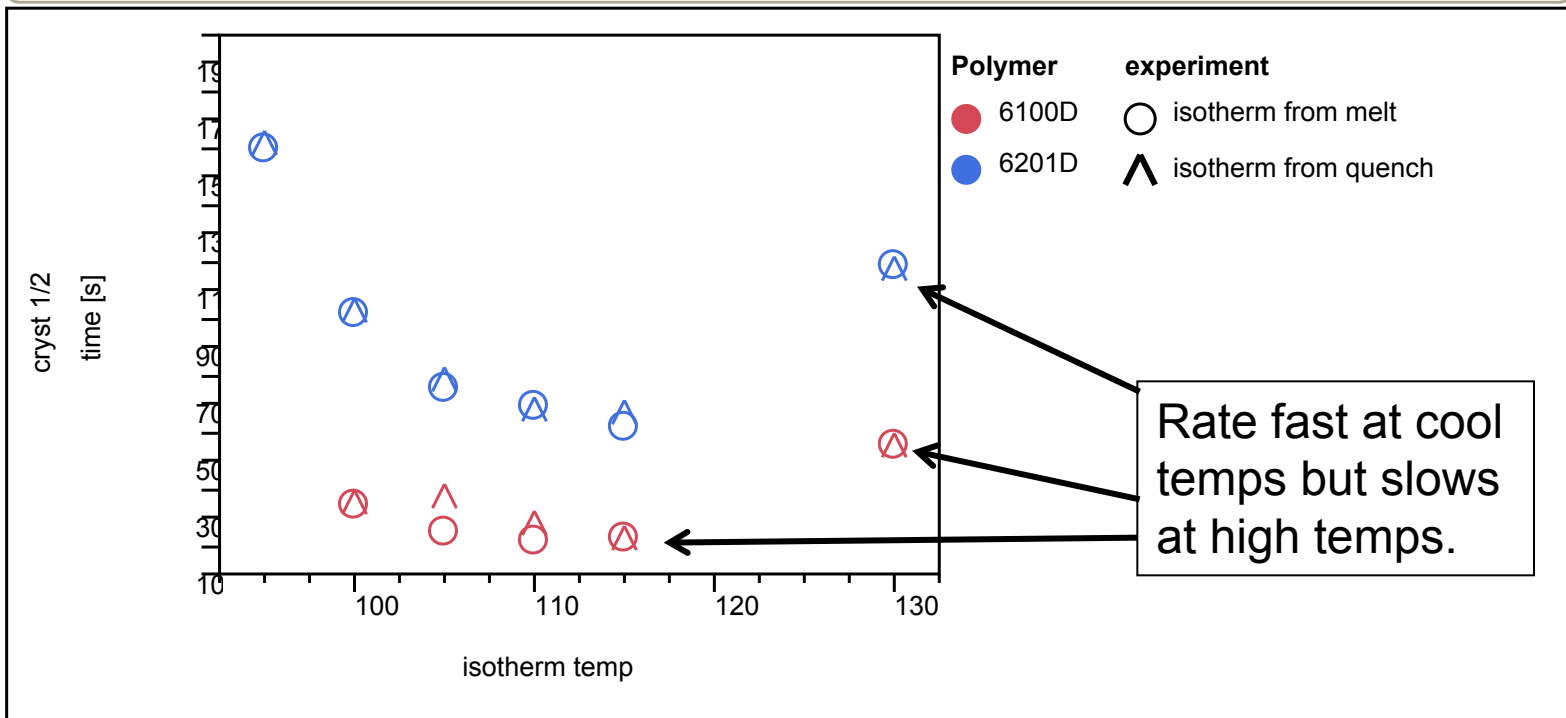

Rate fast at cool temps but slows at high temps.

Ultratalc 609 supplied Specialty Minerals

0.5% EBS nucleant crystallized from the melt and quenched states

Bivariate Fit of cryst 1/2 time [s] By isotherm temp Nucleant=0.5% EBS

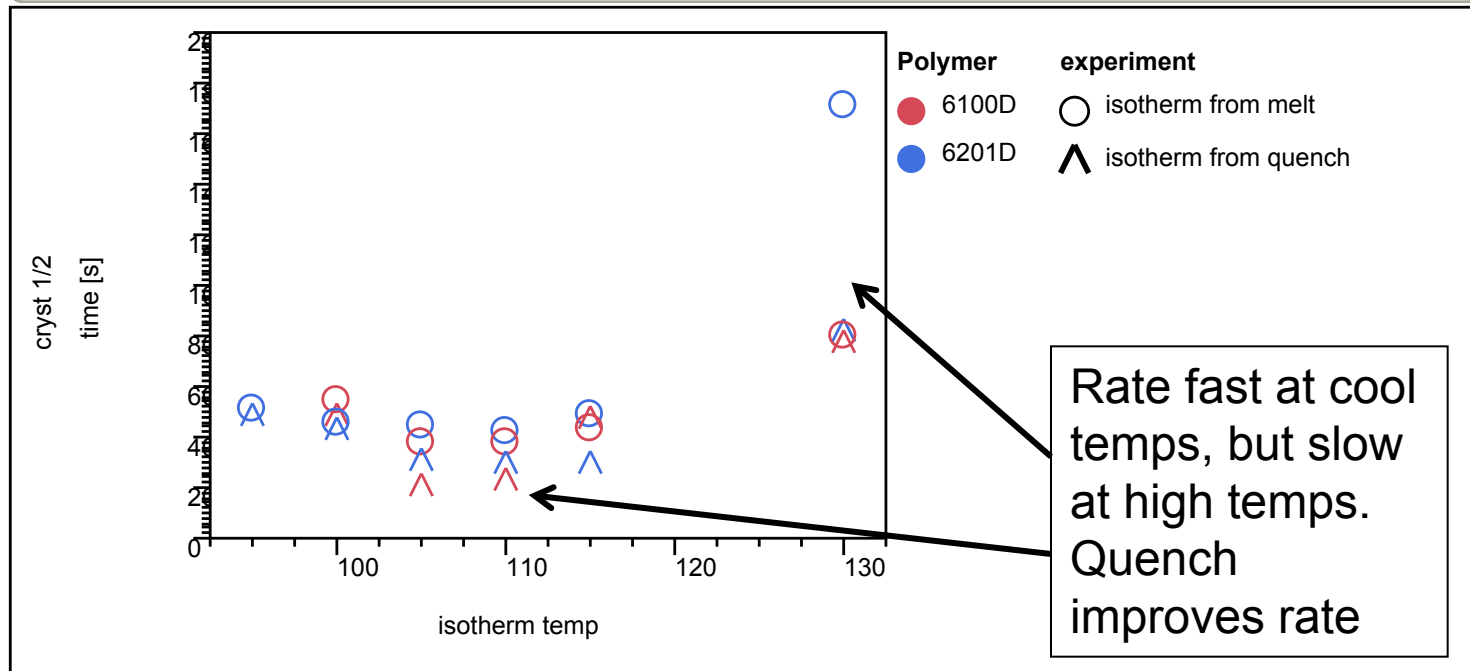

EBS supplied by Crompton

Flash DSC example of collected data 2: Crystallization during rapid heating

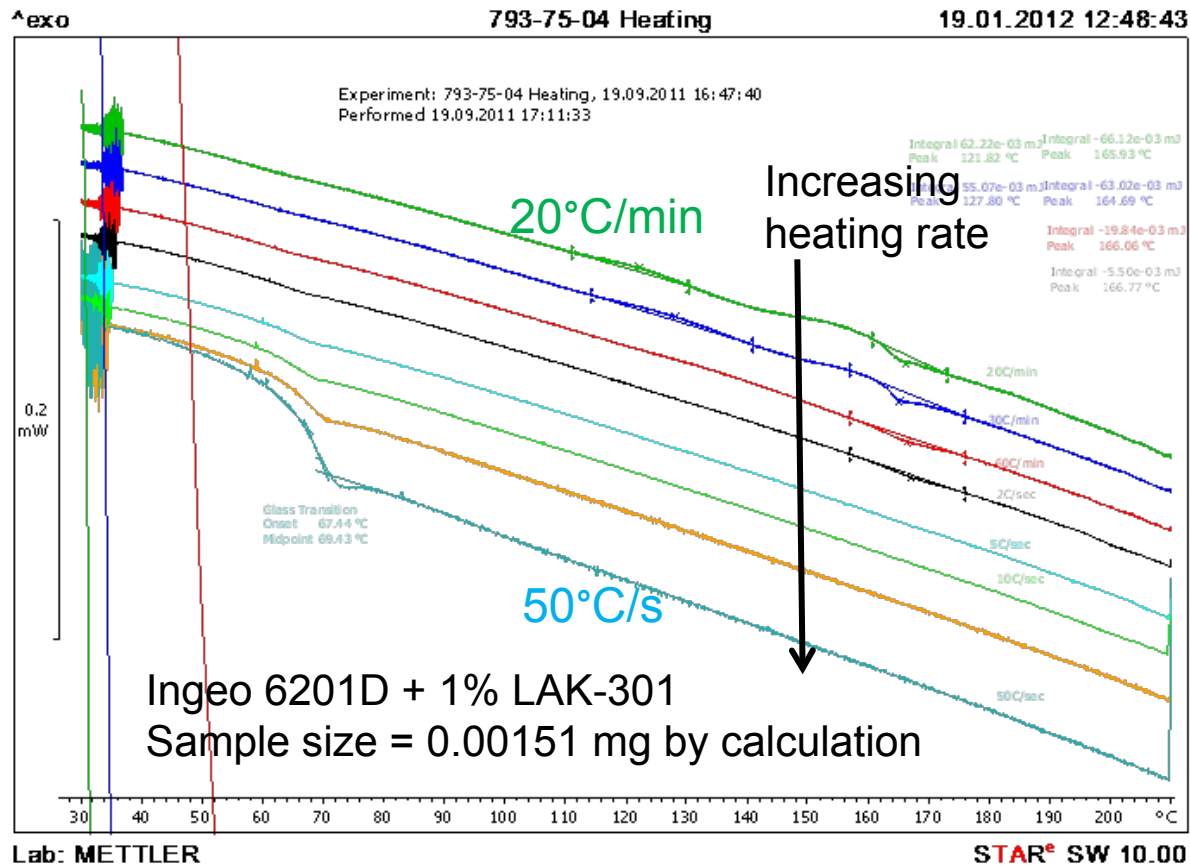

- Signal from material transitions is much stronger at faster rates
- Cold-crystallization is completely suppressed at high rates



Crystallization During Varied Heating Rates

Ingeo 6201D (~1.5%D) vs. 6100D (~0.3%D) at equal MW with Four Nucleants

Analysis of % Crystallinity During Heating

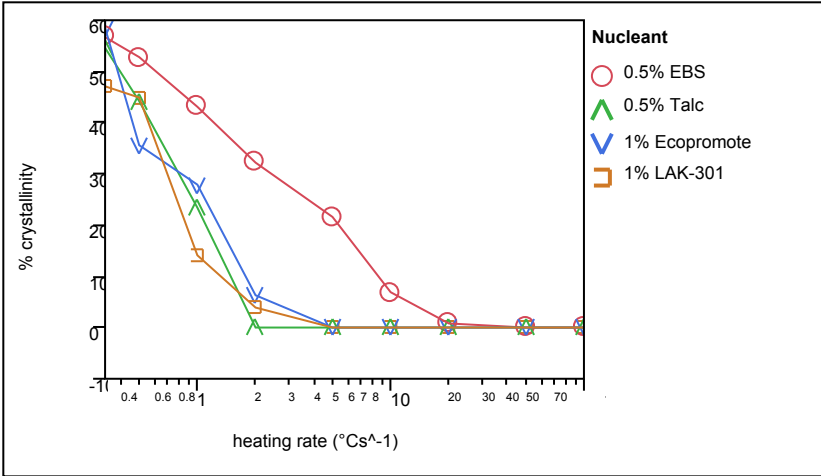

← 6201D + nucleants heating at 0.5-100°C/sec second From the quenched state (30°C)

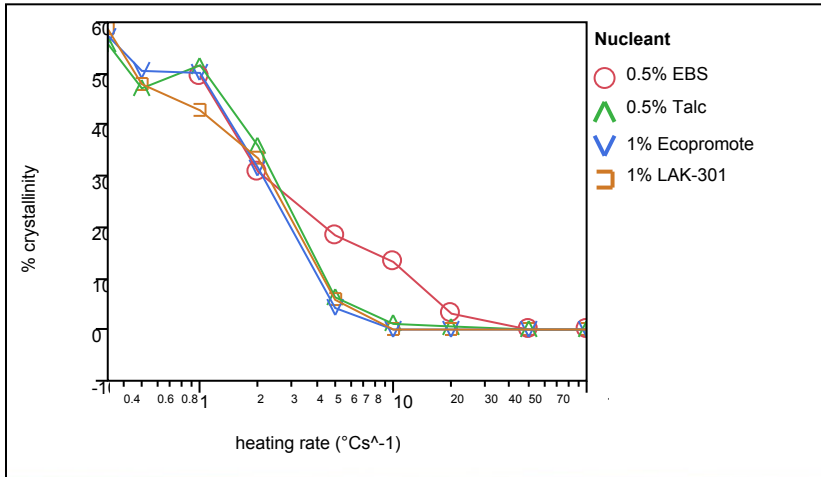

← 6100D + nucleants heating at 0.5-100°C/sec second From the quenched state (30°C)



Crystallization During Varied Cooling Rates

Ingeo 6201D (~1.5%D) vs. 6100D (~0.3%D) at equal MW with Four Nucleants
 Analysis of % Crystallinity During Reheat at 100°C/sec

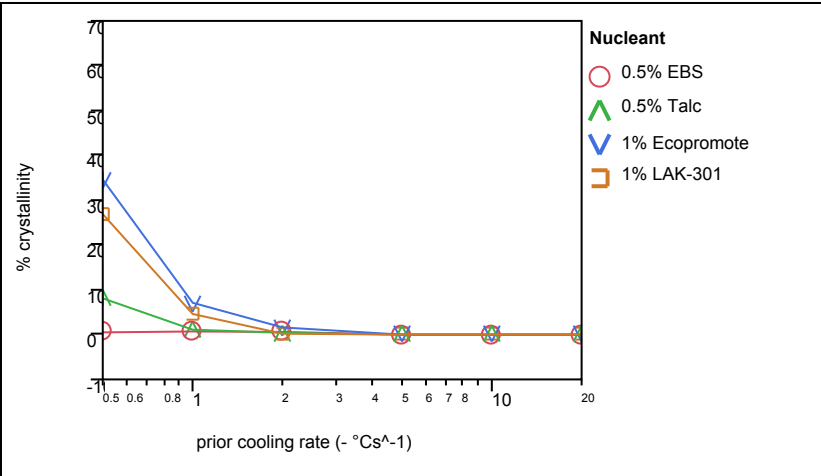

← 6201D + nucleants cooling at 0.5-20°C/sec second
 From the molten state (210°C)

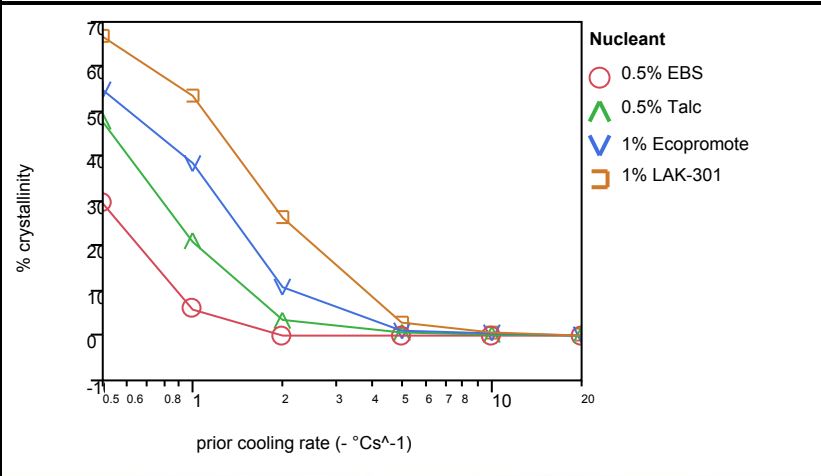

← 6100D + nucleants cooling at 0.5-20°C/sec second
 From the molten state (210°C)



E' Modulus(T) Results: Hot molded bars with nucleant, 3 point bend geometry to measure E'

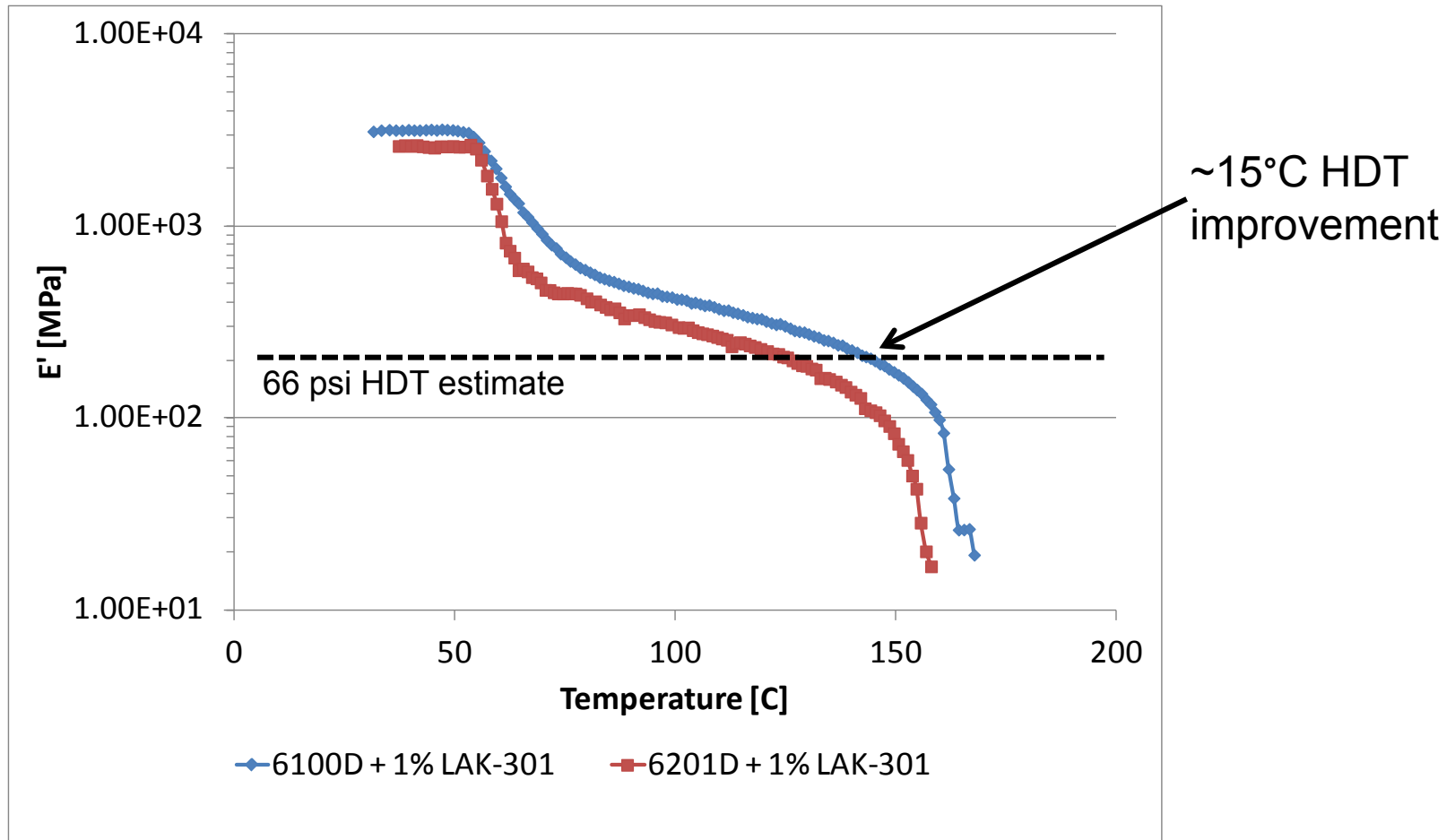

% crystallinity and T_m vs. isotherm time (s) for Polymer=6100D, experiment=isotherm from melt

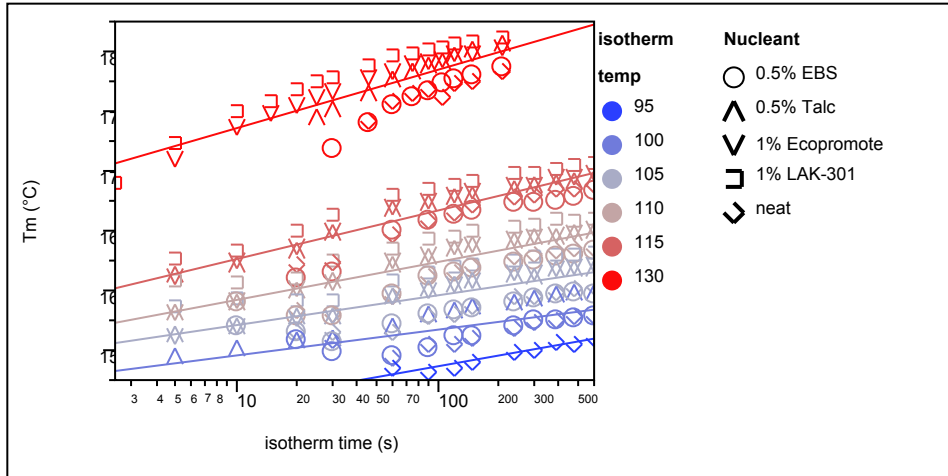

← First examination of the raw data showed incredible variations in observed melting point. Heating rate = 100°C/s

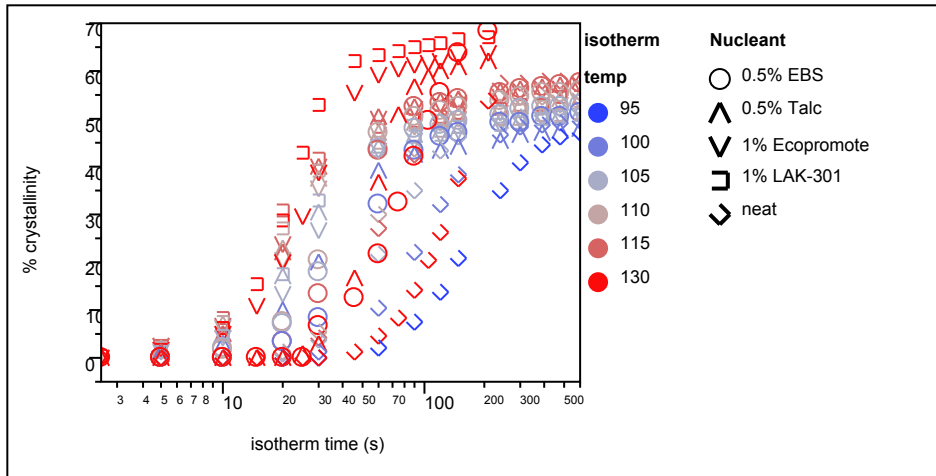

← Large differences in crystallization kinetics and final crystallinity

Compiled data of crystallinity developed during isotherms from both quenched and melt states

Bivariate Fit of T_m (°C) By % crystallinity Polymer=6100D

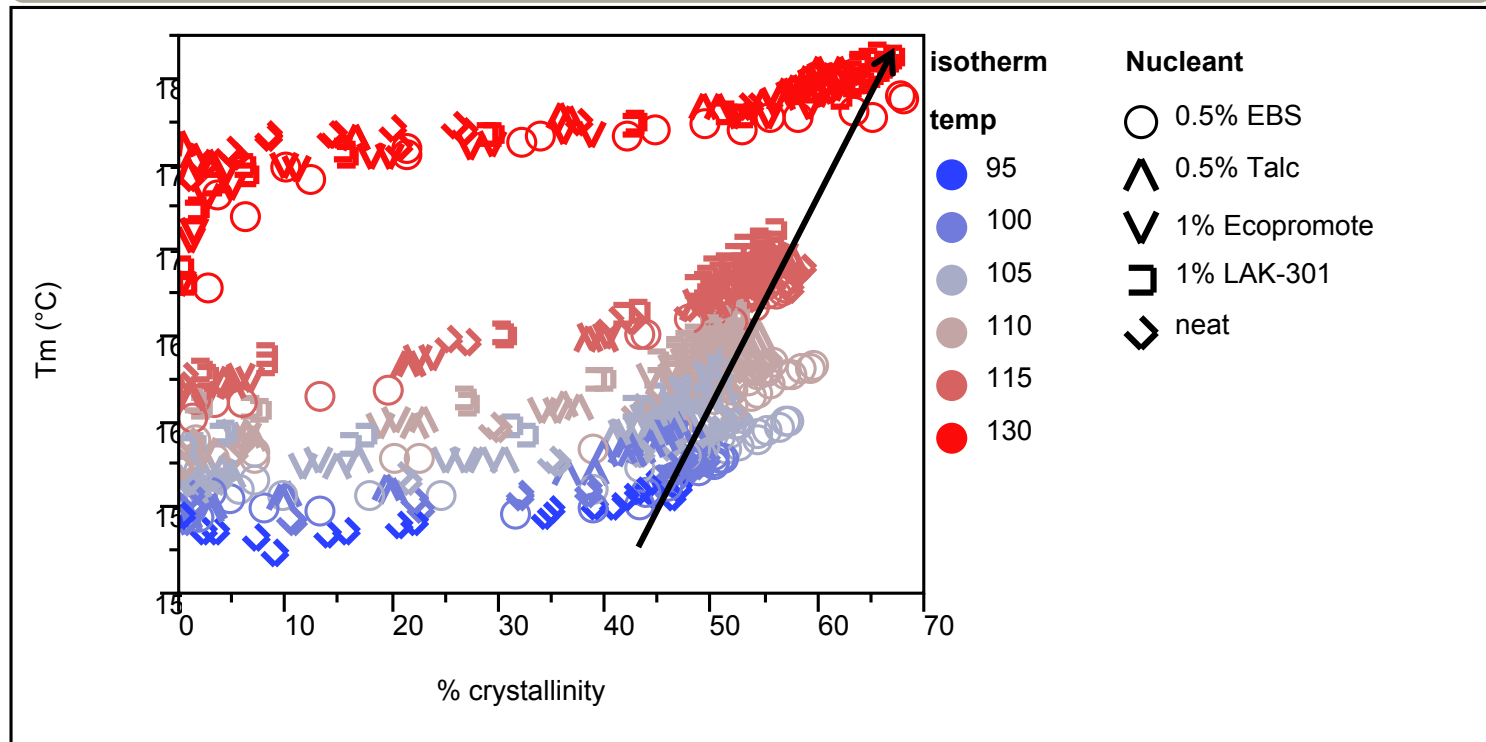

Compiled data of crystallinity developed during isotherms from both quenched and melt states

Bivariate Fit of T_m ($^{\circ}\text{C}$) By % crystallinity Polymer=6201D

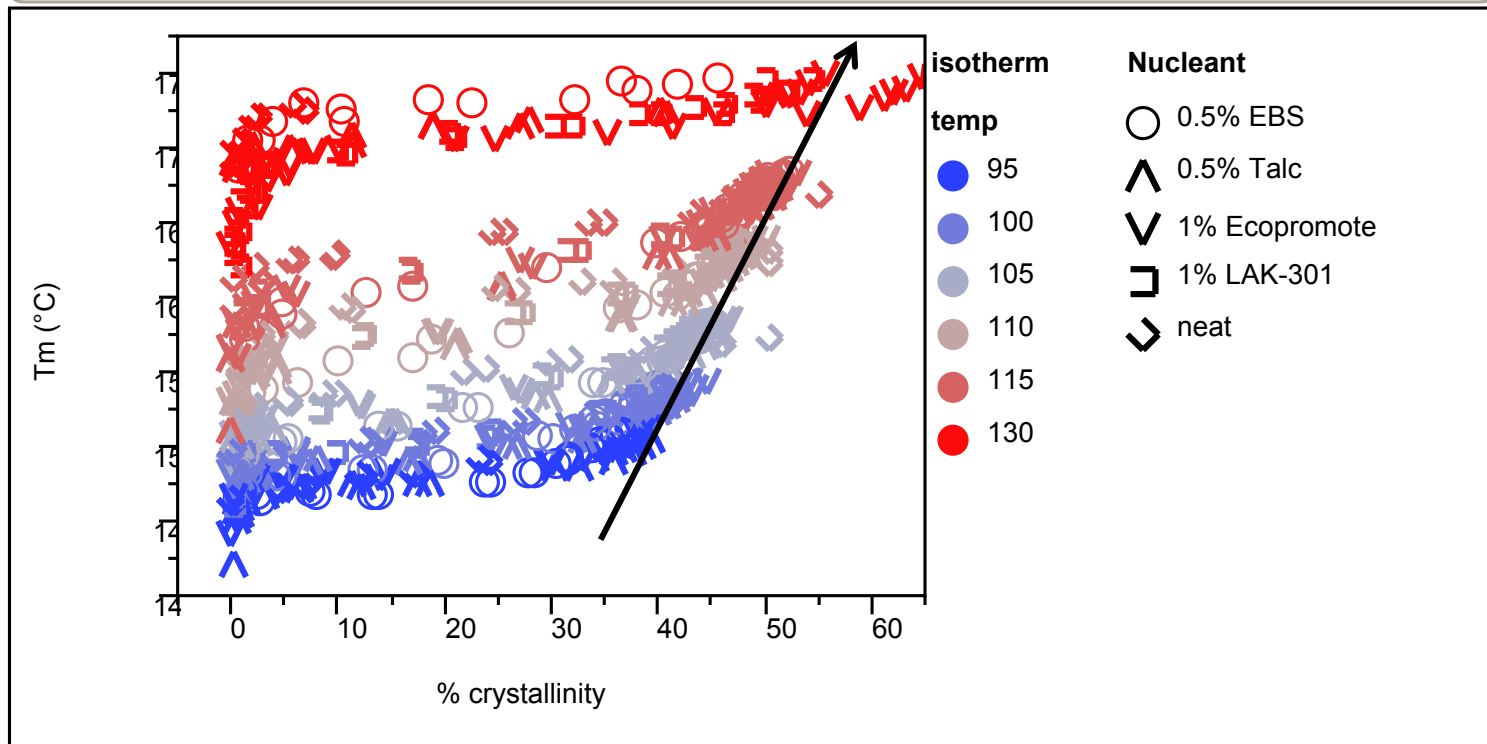

Analysis of variance on final crystallinity*:

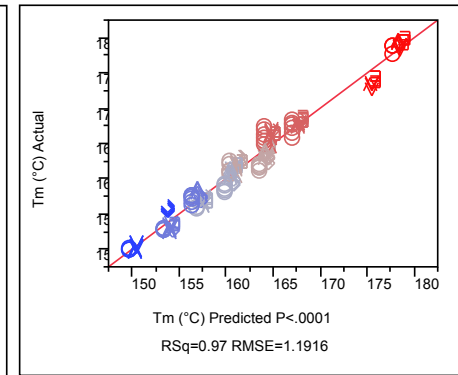
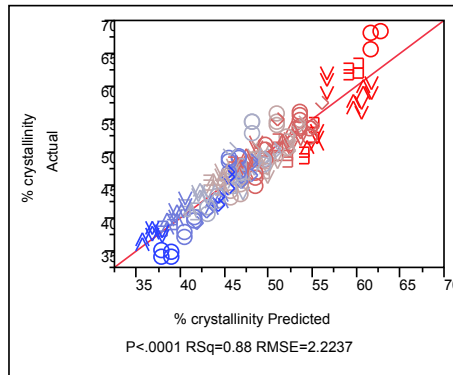

- Isotherm temperature has a strong influence on both % crystallinity and T_m
 - +0.57% absolute crystallinity increase per °C anneal T
 - +0.71°C T_m increase per °C anneal T
- 6100D had 11% relative crystallinity increase and 3°C T_m increase over 6201D
- All nucleants showed similar T_m and % crystallinity to within 1 °C and 3% abs. crystallinity at the end of annealing

*Data selected for Avrami $1-X < 0.05$

$$1 - X = \exp(-Kt^n)$$



Nonwoven Fabrics

Demonstrations with New Grades

- Melt Blown
 - Fine fibers (2-7 micron diameter)
 - Low porosity (filtration)
 - Softness
 - Low orientation (low strength)
- Spunbond
 - High strength to weight ratio
 - Higher fiber diameter (15-35 micron diameter)
 - Geotextile, medical, automotive
 - High degree of orientation



Melt Blown Extrusion Line

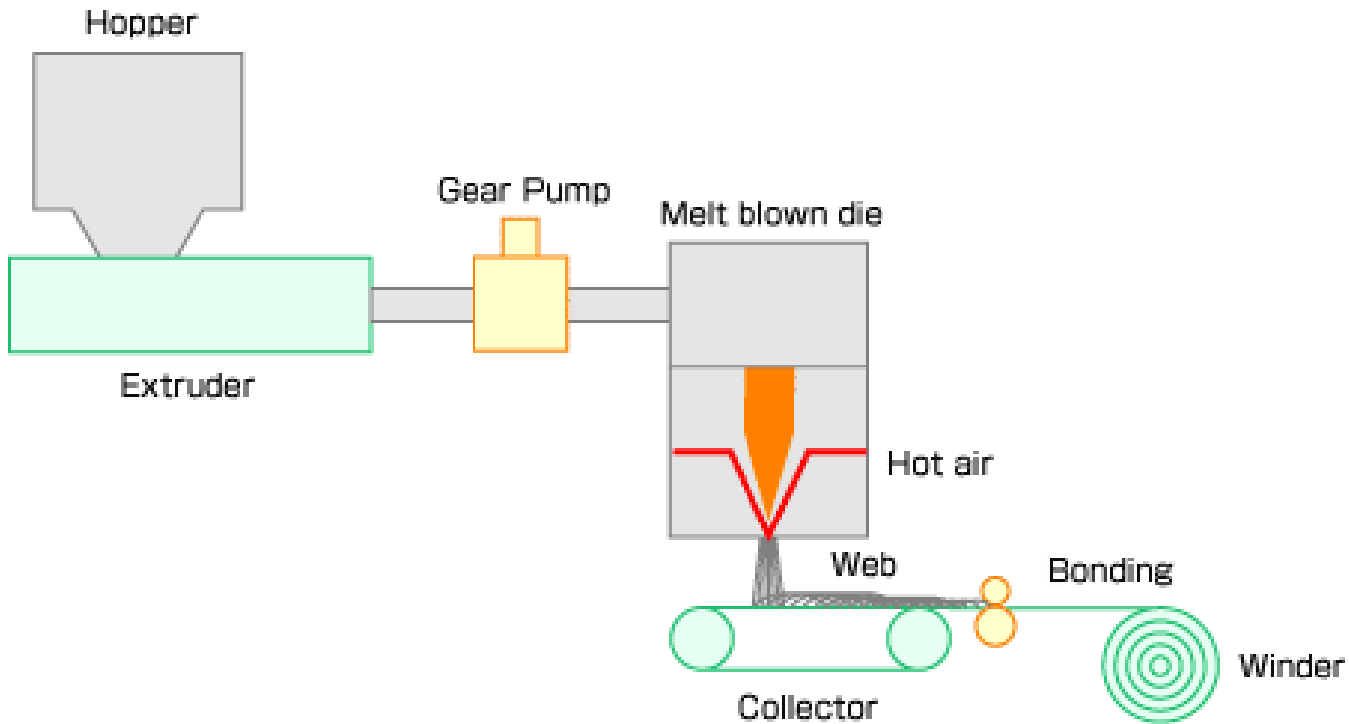

DESIGN OF MICRON
Kasen Nozzle Mfg. Co.,Ltd



Melt blown fibers

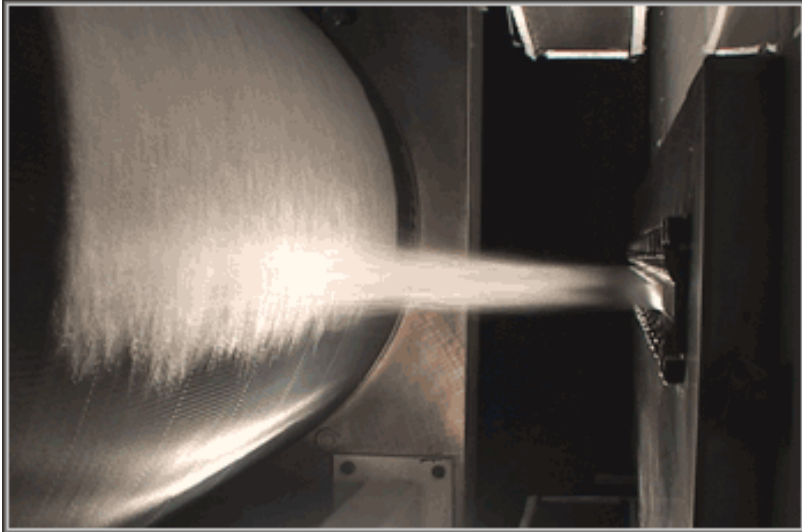

Equipment

6 inch die width

120 holes at 0.245mm (0.010 in) diameter

0.06 inch air gap

0.06 inch setback

30° die angle

15 L/D extruder

Nonwovens Research Lab at The University of Tennessee, under direction of Gajanan Bhat

Melt blown fibers optimized results

Conditions

0.6 g/min/hole

240°C melt temp., ~250 psi melt press.

260°C air temp., ~20 psi air press.

200-220 mm distance from die to collector

30 g/m² basis weight

sample	direction	Fiber Diameters [μm]	100°C hot air shrink [%]	Peak Force [lb]	Peak Elongation [%]
6251D	MD	3.5	27.2	3.1	2.9
6251D	CD		41.3	1.9	25.2
6260D	MD	4.0	4.1	2.7	19.7
6260D	CD		3.5	1.5	31.6



Spunbond Process

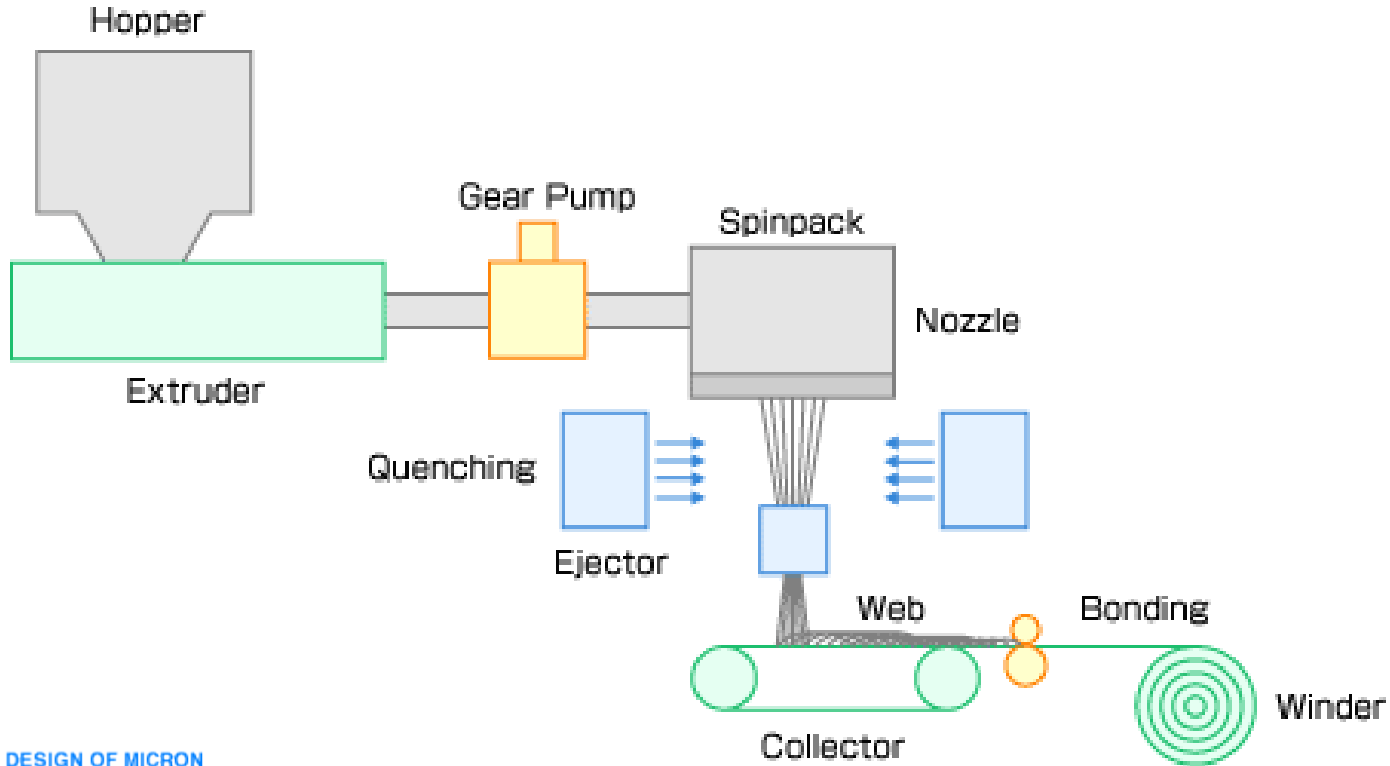

DESIGN OF MICRON
Kasen Nozzle Mfg. Co.,Ltd

Spun bond simulation

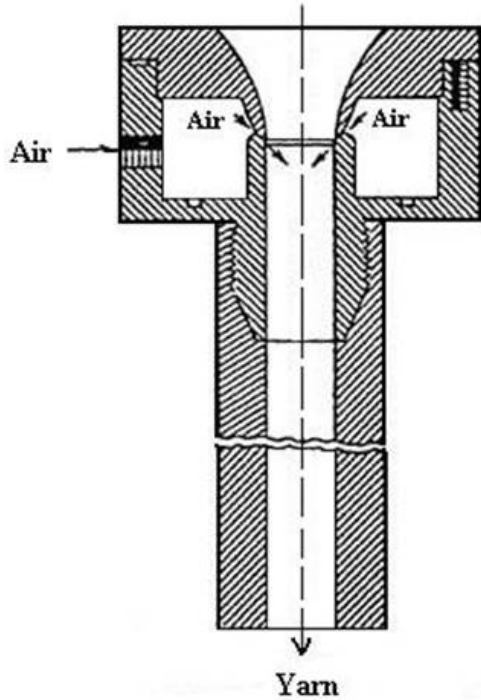

NatureWorks' custom modified Hills
Fiber line with Lurgi fiber attenuator



Lurgi Gun spun bond simulation
 144 holes at 0.3mm diameter
 0.75 g/min/hole
 Draw down range = 18-21
 Filament velocity range = 2800-3800 m/min
 220°C melt temperature, 800-900 psi

Spun bond fiber shrinkage

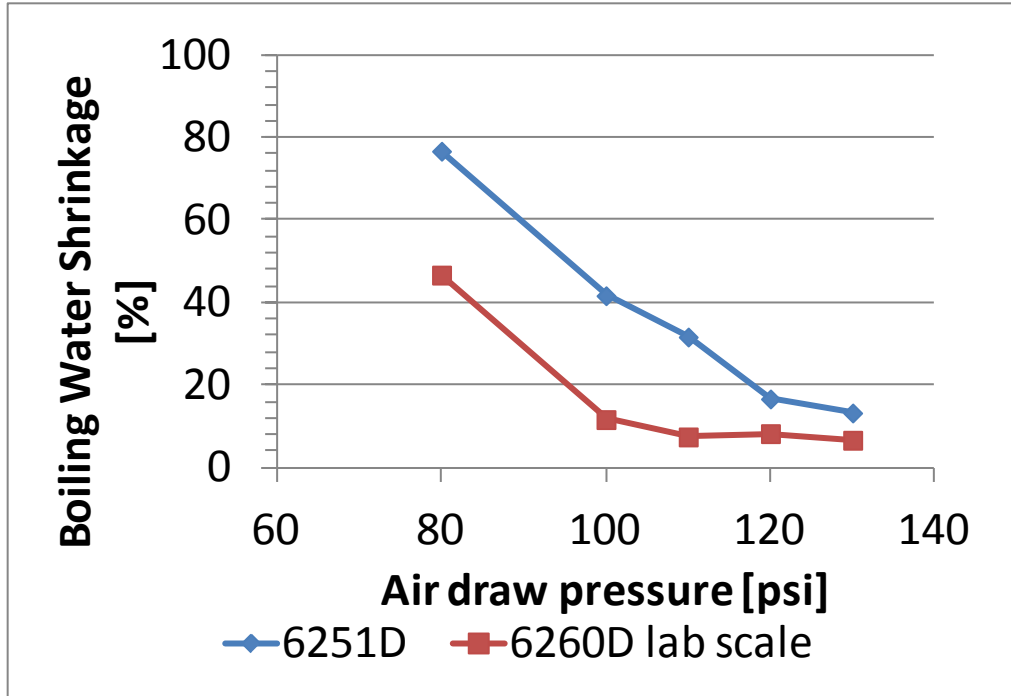

← 6260D processes with lower shrinkage at lower air draw pressures compared to 6251D standard material

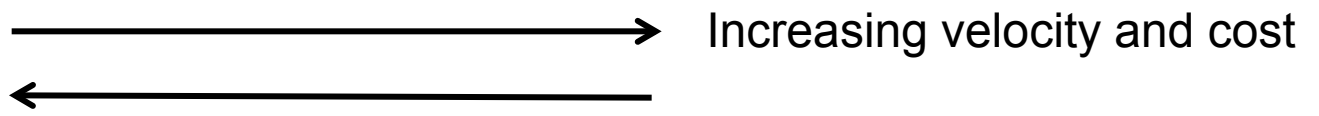

Spun bond fiber strength

Lurgi Gun spun bond simulation
 144 holes at 0.3mm diameter
 0.75 g/min/hole
 Draw down range = 18-21
 Filament velocity range = 2800-3800 m/min
 220°C melt temperature, 800-900 psi

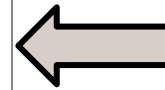
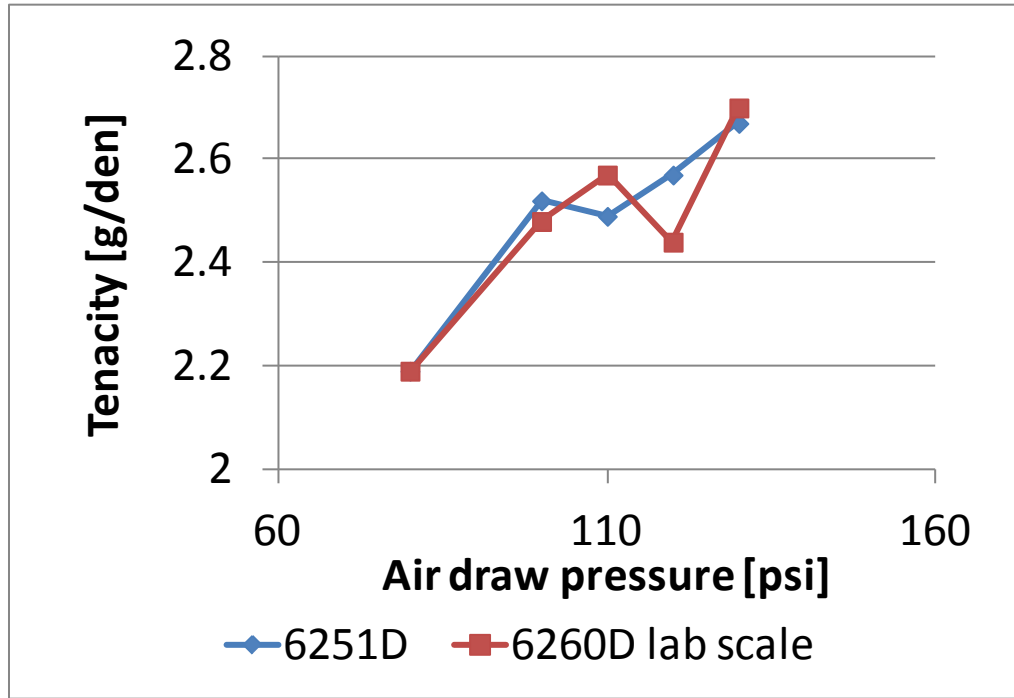

6260D processes has similar strength characteristics as 6251D standard material



Advantages of expanded offering in fibers

- Broad range of applications, with lower shrinkage expected across the board
 - Nonwovens
 - Drawn and heat set fibers
- Higher modulus above T_g
- More hydrolysis resistant
- Heat setting at higher temperatures leads to higher melting / sticking points during processing and use
- Higher T_m has advantages in bicomponent systems, broadening process windows



Advantages of expanded offering for the Durable & Semi-Durable Market

- Compounders can produce more competitive materials
 - Higher productivity during molding
 - Wider processing window
 - Simpler & more cost effective formulations
 - Improves base performance the Ingeo 3801X
- Potential for higher bio-content in formulations
- Higher modulus above T_g , higher HDT
- Higher hydrolysis resistance
- Improved performance in extruded & thermoformed durable applications



Timeline for commercialization

- Ingeo 6100D, 3100HP, 6262D and 3262HP are scheduled to be available 2Q2013
- Expect further publications and process guides from NatureWorks throughout the year

*Note all data shown for Ingeo 6100D and Ingeo 6260D in this presentation were from product development samples, and some changes are expected with large scale commercialization. No descriptions or results shown are specifications for these materials.

